

ADAS向け低インピーダンス高電流チョーク

Key Feature

- Low DCR & High Saturation
- Better thermal stability
- Better conversion efficiency for CCM

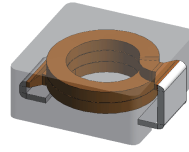

Sample available now!

Vendor	P/N	Value (nH)	Dimensions (Max.)	DCR (mOhm)		Idc (A)		Isat (A)		Max. Operating Tem (°C)
				Typ.	Max.	Typ.	Max.	Typ.	Max.	
T company	HPL505028F080MRD3P	80	5.2*5.2*2.8	0.8	0.88	34		36		155
Cyntec	VCHW053T-70NMS5	70	5.8*5.45*3.0	0.7	0.77	37	33	50	42	155

Efficiency test

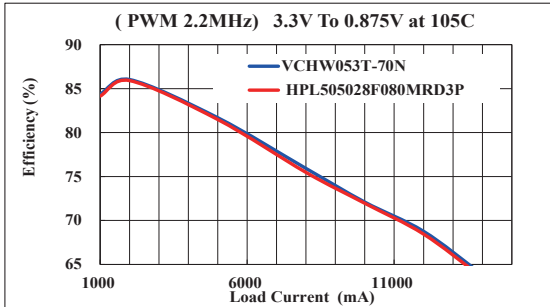

Thermal stability

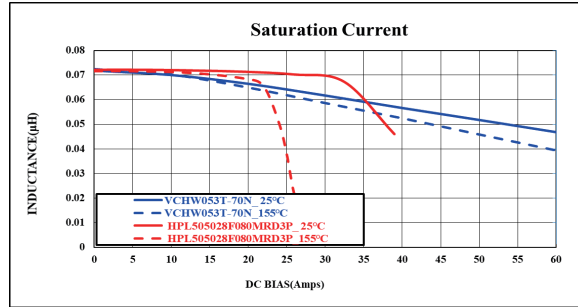

- ✓ Better efficiency at 105C by 0.4% over 10A.
- ✓ High saturated current for lower ripple and better transient response
- ✓ Better thermal stability

CAN & Ethernet コモンモードチョーク

Key Feature

- Metal Lead Frame
- High Mechanical Reliability (Vibration, Shock, Temperature Cycle)
- Products for Different Protocols

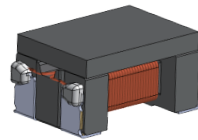

Sample available now!

Standard	IEC62228-3 CiA 110		OPEN Alliance IEEE 802.3 xx		
	Classical CAN	CAN-FD	Ethernet		
Speed	<1Mbps	2Mbitis / 5Mbits	10Base 10Mbps	100Base 100Mbps	1000Base 1Gbits
Products	VFB4532 Series	VFB3225 Series VFC3225 Series VFB4532-101V	VFC3225-131CB (under development)	VFE3225-201	VFE3225-800NB

Low Speed

High Speed

LANトランス LC501AM



Chip LAN Transformer



LAN Common Mode Choke

Outline Dimension

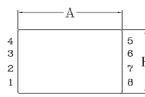

- A = 6.70 MAX./0.264 MAX.
- B = 4.40 MAX./0.173 MAX.
- C = 4.60 MAX./0.181 MAX.
- D = 0.62 MAX./0.024 MAX.
- E = 0.41 MAX./0.016 MAX.
- F = 1.50 MAX./0.059 MAX.

Note: The dimensions had already passed incoming inspection, no need to check Cpk

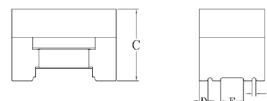

Sample available now!

Schematic

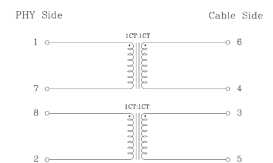

Land Pattern Recommendation

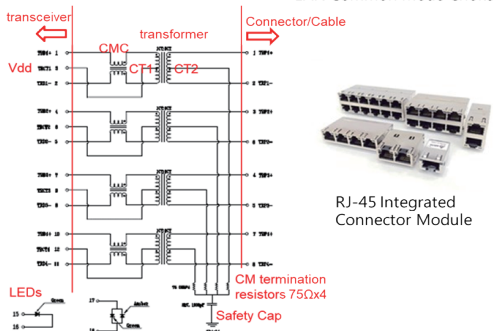
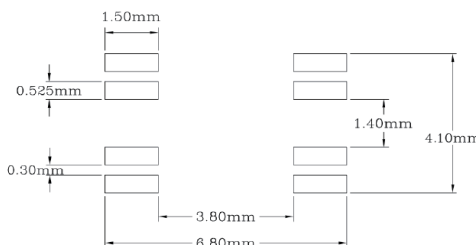

RJ-45 Integrated Connector Module

- Ethernet RJ45 Connector
- Automotive OBD Application
- 4 Pairs, 8 data lines
- 1 CMC and 1 LAN Transformer in each pair
- AEC-Q200 compliance Products